

Mechanical Drawings

PANEL BOARD

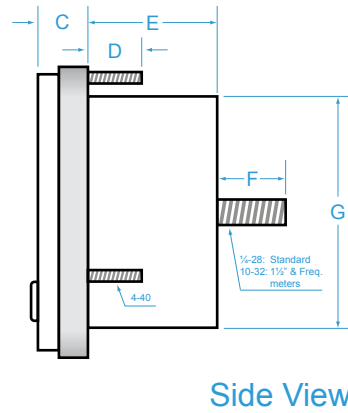

Unit: mm/inches

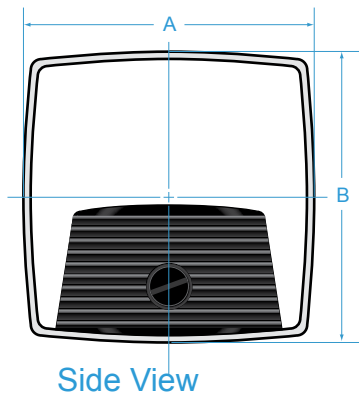
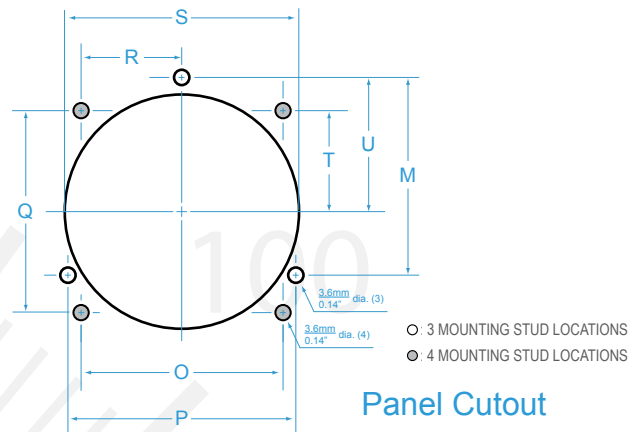
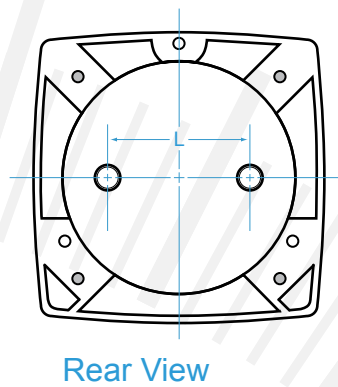

		A	B	C	D	E	F	G	L	M	O	P	Q	R	S	T	U
1.5	mm	44.7	44.7	12.7	12.7	24.4	9.70	38.1	19.0		33.3		33.3	16.7	38.8	16.7	
	in	1.76	1.76	0.50	0.50	0.95	0.38	1.50	0.75		1.312		1.312	0.656	1.53	0.656	
2.5	mm	68.3	68.3	12.7	12.7	30.0	17.0	54.6	33.47	46.5	47.5	53.6	47.5	23.75	55.1	23.75	31.0
	in	2.69	2.69	0.50	0.50	1.18	0.67	2.15	1.318	1.829	1.87	2.112	1.87	0.935	2.17	0.935	1.219
3.5	mm	88.9	88.9	12.7	12.7	30.7	17.0	68.6	33.47	60.27	57.0	69.6	57.0	28.5	69.1	28.5	40.2
	in	3.50	3.50	0.50	0.50	1.21	0.67	2.70	1.318	2.373	2.244	2.74	2.244	1.122	2.72	1.122	1.582
4.5	mm	123.2	112.0	12.7	12.7	30.7	17.0	68.6	33.47		101.6		90.47	50.8	29.1	51.58	
	in	4.85	4.41	0.50	0.50	1.21	0.67	2.70	1.318		4.00		3.562	2.00	2.72	2.031	

Tolerance +0.25mm/+0.01"

Mounting Studs:

PB 1"
2 Studs

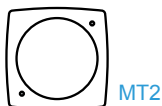

PB 2" & 3"
3 Standard
(4 Optional)

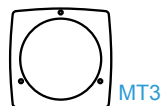

PB 4"
4 Studs

